



British Audio



**OPTIMOST25-V4**

**MOST - TOSLINK 3.0 AUDIO INTERFACE**

























**OPTISOUND**

# Owners Manual

Congratulations on purchasing your VIBE adaptor. Please read this manual in order to fully understand how to get the best results from this product and ensure that all advice on how to look after the product is followed.

Thank you for buying VIBE, we hope you enjoy listening to your product as much as we enjoyed creating it.

## Compatibility

AUDI / VW	06		MMI2G,3G	BMW	02		E/F SERIES
	11		MMI3G+ TOUREG NF		0A		E/F SERIES (PARK)
	13		MMI3G+ LAMBORGHINI		15		E65/E66 AUDIO - OFF
MERCEDES	01		<2008 NTG2.5 NTG4, NTG4.5	17		E65/E66 AUDIO - ON	
	03		>2008 NTG1, NTG2	PORSCHE	14		<2009
	1D		NTG1,c AGW w211, w220		0B		>2009
	1E		NTG3, NTG3.5 c AGW BECKER	VOLVO	05		S60
LAND ROVER	07		FREELANDER 2 HSE		0D		XC70 <2012
	09		FREELANDER 2 S80, XC70-2012		0F		XC90 S40
	0E		>2012 RR SPORT DISCO 3,4		16		XC60 PREMIUM
	08		<2012 EVOQUE DISCO 4, SPORT	00		SERIAL NUMBER	
				  JUMPER CONFIGURATION			

## Limited Warranty

All VIBE products carry a full 12 month warranty, valid from the date of the original receipt and proof of purchase. The online warranty card should be completed within seven days of the original purchase date. The original receipt and packaging should be retained for this twelve month period. If the product develops a problem any stage during the warranty period, it should be returned to the point of purchase in it's original packaging, and complete with no items missing. If the store is unable to repair the product it may have to be returned to VIBE.

A full description of VIBE's warranty information can be found on our website:

**[www.vibeaudio.co.uk](http://www.vibeaudio.co.uk)**

### What Is Not Covered

- Damage to product due to improper installation.
- Subsequent damage to other components.
- Damage caused by exposure to moisture, excessive heat, chemical cleaners and / or UV radiation.
- Damage through negligence, misuse, accident or abuse. Repeated returns for the same fault may be considered abuse.
- Any cost or expense related to the removal and / or re-installation of the product.
- Damage caused by amplifier clipping or distortion.
- Items repaired or modified by any unauthorised repair facility.
- Return shipping on non defective items.
- Products returned without a returns authorisation number.
- Damage to product due to use of sealant.

### International Warranty

Contact your international VIBE dealer or distributor concerning specific procedure for your country's warranty policies. [www.vibeaudio.co.uk/warranty](http://www.vibeaudio.co.uk/warranty)

### Warning

VIBE equipment is capable of sound pressure levels that can cause permanent damage to your hearing and those around you. Please use common sense when listening to your audio system and practice safe sound.

### Copyright

All content included in this manual such as text, graphics, logos, icons, images and data, are the property of Midbass Distribution Limited t/a VIBE Technologies Limited (herein referred to as "VIBE", "us" or "we") and its affiliate or their content and technology providers, and are protected by United Kingdom and International copyright laws. All rights reserved. VIBE TV, VIBE Arcade, Bass Box, Optisound, Cinesound, BlackAir, BlackBox, Space, LiteAir, SLICK, BlackDeath, Bubonic, Reaper, Anti-VIBE, FastPlug, BlackHole, QB69, VIBE Turbo Port, Vibe TurboVent, Pressure Board, Super Driver, VIBE Pulse, VIBE Power, VIBE Digital, VIBE MAG Plugs, Ferrite Loaded, VIBE Solid Core, VIBE OCC, VIBE FLAT, ICC, Bass Enhance, Bass Enhance+, QBass, SpeedBass, PowerBass, N-Wedge, Box Grip, ARBSS, Supercar Series and all stylised representations of product names, or the abbreviations of product names, as logos are all trademarks of VIBE. Graphics and logos are trademarks or trade dress of VIBE Technologies Ltd or its subsidiaries. VIBE's trademarks and trade dress may not be used in connection with any product or service that is not VIBE's, in any manner that is likely to cause confusion among customers or in any manner that disparages or discredits VIBE. All other trademarks not owned by VIBE or its subsidiaries that appear in this manual are the property of their respective owners, who may or may not be affiliated with, connected to, or sponsored by VIBE or its subsidiaries.

TO THE FULLEST EXTENT PERMITTED AT LAW, VIBE IS PROVIDING THIS MANUAL AND ITS CONTENT ON AN "AS IS" BASIS AND MAKES NO (AND EXPRESSLY DISCLAIMS ALL) REPRESENTATIONS OR WARRANTIES OF ANY KIND, EXPRESS OR IMPLIED, WITH RESPECT TO THIS MANUAL OR THE INFORMATION, CONTENT, MATERIALS OR PRODUCTS INCLUDED IN THIS MANUAL INCLUDING, WITHOUT LIMITATION, WARRANTIES OF MERCHANTABILITY AND FITNESS FOR A PARTICULAR PURPOSE. IN ADDITION, VIBE DOES NOT REPRESENT OR WARRANT THAT THE INFORMATION CONTAINED IN THIS MANUAL IS COMPLETE OR CURRENT, AND THAT ALL SPECIFICATIONS AND INFORMATION CONTAINED WITHIN THIS MANUAL ARE SUBJECT TO CHANGE WITHOUT NOTICE. VIBE RECOMMENDS CAUTION WHEN LISTENING TO MUSIC REPRODUCED THROUGH VIBE EQUIPMENT. VIBE EQUIPMENT IS CAPABLE OF PRODUCING SOUND AND SOUND PRESSURE LEVELS THAT CAN PERMANENTLY DAMAGE HEARING OF YOU AND THAT OF OTHERS. FOR SAFE AND ENJOYABLE LISTENING, THE SOUND SHOULD BE CLEAR WITHOUT DISTORTION AT A COMFORTABLE VOLUME. BY USING ANY VIBE EQUIPMENT, YOU AGREE TO TAKE FULL RESPONSIBILITY FOR YOUR OWN SAFETY AND THE SAFETY OF OTHERS WHEN LISTENING TO MUSIC AT HIGH VOLUMES THROUGH EQUIPMENT YOU HAVE PURCHASED. USE OF ANY VIBE EQUIPMENT CONSTITUTES AGREEMENT TO THIS DISCLAIMER. Except as specifically stated in this manual, to the fullest extent permitted at law, neither VIBE nor any of its affiliates, directors, employees or other representatives will be liable for damages arising out of or in connection with the use of this manual or the information, content, materials or products included. This is a comprehensive limitation of liability that applies to all damages of any kind, including (without limitation) compensatory, direct, indirect or consequential damages, loss of data, income or profit, loss of or damage to property and claims of third parties. For the avoidance of doubt, VIBE does not limit its liability for death or personal injury to the extent only that it arises as a result of negligence of VIBE, its affiliates, directors, employees or other representatives.

## Power Connections

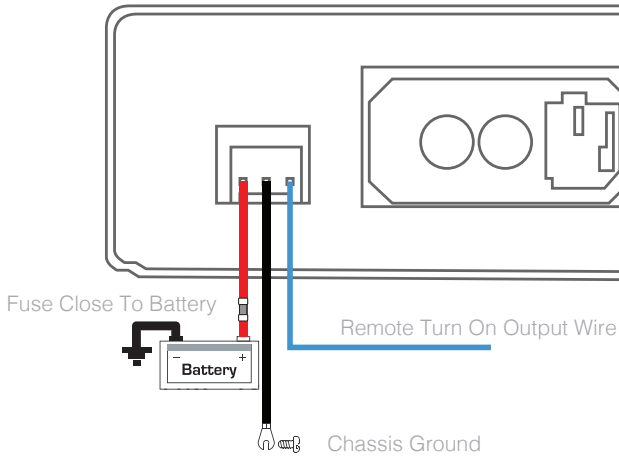

## MOST Connections

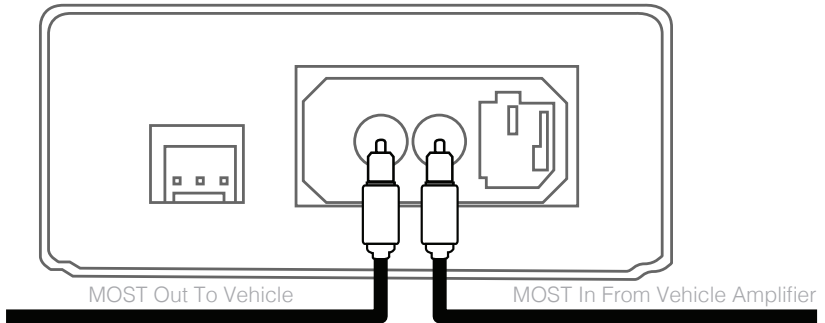

## Optical Connection

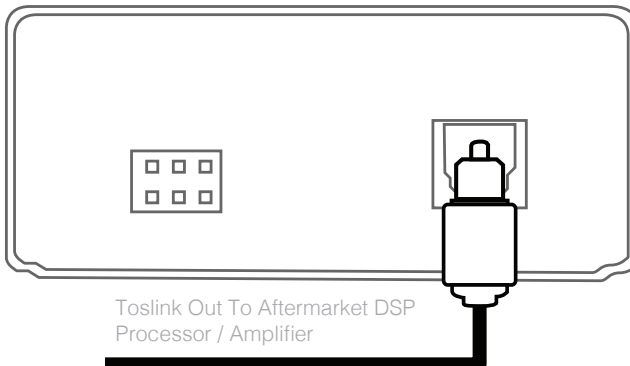

## Installation Notes

Please note that the power connections may not match those present in the vehicle, please ensure that the correct connections are made using a multi-meter. Incorrect wiring may cause damage to the adaptor that isn't covered by warranty.

## Connections

### 1. Set the jumpers correctly for your vehicle and model.

Used to connect to the low level (RCA) output of your source (head unit) to the amplifier.

### 2. Connection procedure.

- Connect MOST connections from the vehicle amplifier to the OPTIMOST25-V4.
- Connect power cables +12V (red wire) GND / Ground (black wire), REM out (blue wire)
- Connect Toslink cable from OPTIMOST25-V4 to digital sound processor (DSP) or amplifier with Toslink input.

## Terminals And Connections

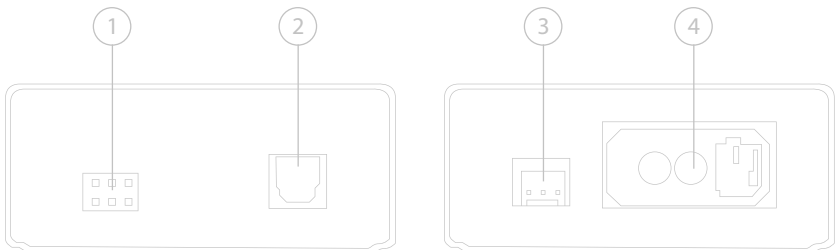

### 1. Low level input

Used to connect to the low level (RCA) output of your source (head unit) to the amplifier.

### 2. Optical Output

Use an optical Toslink cable (not supplied) to connect the OPTIMOST25-V4 to an aftermarket amplifier or

DSP processor with Toslink input.

### 3. Power terminals

Used to connect DC power to the OPTIMOST24-V4 and supply a remote turn on wire for an aftermarket amplifier / DSP processor.

See the power connections section for more details.

### 4. MOST Input / Output

Used to connect the OPTIMOST25-V4 to the vehicles MOST bus.

## Application Special Mode For BMW

If you want to change the volume levels of parking sensors and system messages, you should use an additional mode of the OPTIMOST25-V4

To set the desired volume of the parking sensors and signals:

- 1) set the jumpers to position BMW (one jumper).
- 2) Turn on the system.
- 3) Without turning off the system, add a jumper (position "BMW spec.mode (park)").
- 4) Adjust the level of the lower border signals by adjusting low frequency timbres. The signal level will not drop below this level.
- 5) Adjust attenuation additional signals relative to the level of the main channel by adjusting the timbres of the upper frequency (lowering of the signal levels of the parking sensors and of the system relative to the main music signal).
- 6) Turn off the system and wait until the car goes into standby.
- 7) With the parameters set, return the jumpers to the default settings for the BWM model.

## Notes:

### Audio Playback

- The OPTIMOST25-V4 does not include a surround sound processor and multi-channel sound decoders, so the "Logic-7" effect is not supported, and DVD playback of multi-channel audio formats (Dolby Digital, Dolby Pro Logic II, DTS, SDDS, etc.) is not possible.
- The OPTIMOST25-V4 MOST-TosLink creates output 24-bit stereo audio via TOSLINK optical output (IEC-60958, S/PDIF) 44.1(48)kHz 24 bit stereo PCM.





### Radio Interference

- The OPTIMOST25-V4 uses a switching power supply to reduce the potential of radio interference, and is mounted in a metal case, which is a radio screen. Due to the metal body, the level of radio interference from the device is extremely low. In addition, electronic components with optimal parameters are used in the schematic of the OPTIMOST25-V4 to reduce and potential impact on radio reception. The only source of radio interference when using these interfaces can be electrical wires connected to the unit. With high-quality performance of the standard radio module, the OPTIMOST25-V4 is not able to interfere with its operation.





### Tips To Reduce Radio Interference

- Do not have the OPTIMOST25-V4 and cables connected within the vicinity of the radio antenna, antenna cable and blocks associated with the radio.
- Power wires (Batt and GND) are recommended to be laid together with each other (can be twisted pair). Since the Batt and GND wires create antiphase when twisted together wires will have zero activity. If it is impossible to twist power wires together then it is possible to reduce influence of power wires if the user includes a capacitor (0,1 ... 100,0 mkF, voltage over than 16 volts) with low value of ESR between these wires. The placement of the capacitor and its nominal value will need some experimentation to achieve best results in the installed vehicle.
- The location where the power wires are connected to the car's wiring can make a difference, especially important is the distance from the interface connection points to the power connection points of the standard radio module (the result can be affected by both reducing and increasing this distance).
- It is also good practice to not run the Remote Out control wire in close proximity to the radio antennas. The length of the Remote Out wire should be as small as possible. If you cannot use a short Remote Out wire, you can use a shielded wire as the line.
- The optimal ground point of the screen can be located near the ground of the standard radio receiver).

## Jumper Settings







Jumper position	Compatibility	Notes
1E 	Mercedes Benz (NTG3 and NTG3.5 audio systems, audio systems with AGW block the production of Becker).	The AGW block (Becker) is significantly larger than the AGW block (Japan). In systems equipped with an AGW (Japan) unit, it is not possible to connect the radio audio channel to an external amplifier. Distinctive feature: systems with AGW (Becker) support Logic-7 function, and systems with AGW block (Japan) do not support it. Regular amplifier is stored in the system (combined with radio tuner). The interface is connected to the MOST-25 in front of a regular amplifier (combined with a radio tuner) in the course of light. After connecting the interface, the standard amplifier cannot play sound.
01 	Mercedes Benz 2008+ (NTG2.5, NTG4, NTG4.5).	The standard amplifier is disconnected and the OPTIMOST25-V4 is connected in its place in the MOST bus.
03 	Mercedes Benz until 2009 (NTG1 without external unit the AGW and NTG2).	The standard amplifier is disconnected and the OPTIMOST25-V4 is connected in its place in the MOST bus.
1D 	Mercedes Benz (NTG1 audio system with the external unit AGW) - W211, W219, W220.	Regular amplifier is stored in the system (combined with radio tuner). OPTIMOST25-V4 is connected to any position MOST-25. The standard amplifier remains active and can play sound to the speakers in normal mode.
15 	BMW E65, E66	The non-standard amplifier should be connected to the speakers that were connected to the dismantled standard amplifier. The non-standard amplifier only plays a stereo signal. The head unit generates service signals to the front and rear speakers and plays a stereo signal to the front speakers. Rear acoustics head unit forms the only service signals.

## Jumper Settings

Jumper position	Compatibility	Notes
17 	BMW E65, E66	The non-standard amplifier should be connected to the speakers that were connected to the dismantled standard amplifier. The non-standard amplifier only plays a stereo signal. The head unit generates service signals to the front and rear speakers and plays a stereo signal to the front speakers. Rear acoustics head unit forms the only service signals.
02 	BMW E60, E61, E63, E64, E70, E71, E72, E90-E93. BMW F01, F02, F03, F07, F10, F11, F12, F13, F16, F20, F25, F30.	The standard amplifier is disconnected and the OPTIMOST25-V4 is connected in its place in the MOST bus.
0A 	BMW E60, E61, E63, E64, E70, E71, E72, E90-E93. BMW F01, F02, F03, F07, F10, F11, F12, F13, F16, F20, F25, F30, F31, F34.	Special mode for BMW, use to force the specified options signal PDC. The standard amplifier is disconnected and the OPTIMOST25-V4 is connected in its place in the MOST bus.
06 	AUDI A4, A5, A6, A8, Q5, Q7 (MMI 2G, 3G) with separate external amplifier.	The standard amplifier is disconnected and the OPTIMOST25-V4 is connected in its place in the MOST bus.
11  13 	AUDI A4, A5, A6, A8, Q5, Q7 (MMI 3G+), Lamborghini (amplifier with radio tuner in a single unit).	Regular amplifier is stored in the system (combined with radio tuner). The OPTIMOST25-V4 is connected to any position in the MOST bus. Once the OPTIMOST25-V4 is connected, the standard amplifier cannot play audio. See Notes for more information.
0B 	Porsche until 2009 (Cayenne, etc. with PCM2.0 and PCM2.1).	The standard amplifier is disconnected and the OPTIMOST25-V4 is connected in its place in the MOST bus.
14 	Porsche 2009+ (Cayenne, etc. with head unit PCM3.0)	The standard amplifier is disconnected and the OPTIMOST25-V4 is connected in its place in the MOST bus.
09 	Volvo S80, XC70 until 2012, Land Rover Freelander 2	The standard amplifier is disconnected and the OPTIMOST25-V4 is connected in its place in the MOST bus.
07 	Land Rover Freelander 2 (HSE)	The standard amplifier is disconnected and the OPTIMOST25-V4 is connected in its place in the MOST bus.



## Jumper Settings

Jumper position	Compatibility	Notes
0D 	Volvo XC70 2012+ and some models Volvo S60, V60	The standard amplifier is disconnected and the OPTIMOST25-V4 is connected in it's place in the MOST bus.
05 	Volvo S60, V60	The standard amplifier is disconnected and the OPTIMOST25-V4 is connected in it's place in the MOST bus.
16 	Volvo XC60 Premium	The standard amplifier is disconnected and the OPTIMOST25-V4 is connected in it's place in the MOST bus.
0F 	Volvo XC90, S40, V50	The standard amplifier is disconnected and the OPTIMOST25-V4 is connected in it's place in the MOST bus.
0E 	LR Discovery-3, Discovery-4 until 2013, RR Sport until 2012.	The standard amplifier is disconnected and the OPTIMOST25-V4 is connected in it's place in the MOST bus.
0B 	Range Rover Evoque, Range Rover Sport2012+, LR Discovery-4 2013+	The standard amplifier is disconnected and the OPTIMOST25-V4 is connected in it's place in the MOST bus.
00 	Volvo, Land Rover, Range Rover with activated protective coding system.	This mode is designed to read the serial number (hereinafter S/N) from the standard amplifier for further use of S/N interface MOST-TosLink or MOST-RCA for correct operation of the system. S/N reading is only necessary when the vehicle is equipped with a protective coding system. When the protective coding system is activated, the amplifying equipment is always switched on normally, after which the S/N of all system units is checked. If The S/N equipments is correct, the system continues to operate, but if the S/N amplifier unit is incorrect, then any change in the audio source will cause the equipments to stop functioning. To read the S/N interface is connected to any position on MOST-25. The regular amplifier must remain in the system during the S/N reading procedure.

## Notes for AUDI 3G+ and VW Touareg NF

In multimedia systems AUDI 3G+ and VW Touareg NF feature a power amplifier located in a single unit with a radio tuner. For this reason, when you install the OPTIMOST25-V4, the standard amplifier remains connected to the MOST network with the adapter being installed. Configuration of a standard system that allows the installation of an additional external power amplifier is theoretically possible, but to date there is no information on how to program such a configuration. If the standard system is programmed to work with an external separate amplifier, the position of the jumpers No. 06 "AUDI 2G" should be used for the OPTIMOST25-V4.

In General, when the system is turned on, the standard head unit is connected via the MOST interface to two amplifiers instead of one (the second amplifier is the connected OPTIMOST25-V4). Since the basic version of the standard system is not designed to work with two amplifiers, this fact creates the prerequisites for errors in the appointment of sound channels. During the development of the OPTIMOST25-V4, the relevant studies were carried out, as a result of which special algorithms were created to neutralize errors in the assignment of audio channels. OPTIMOST25-V5 and AUDI 3G+ and VW Touareg NF in fact not only perform its primary task. They monitor the purpose of the audio channels and cause reinitialization of the system when an error is detected. Because different software versions in automotive systems react differently to the presence of two amplifiers in the system, the problem of error recognition does not have a universal solution. The universal solution for the system performance in this case will be only programming the system to work with a separate external amplifier and installing jumpers in the position № 06 "AUDI 2G".

Recommendations for those cases when the system "AUDI 3G +" or "VW Touareg NF" cannot be programmed to work with an external separate amplifier, and when you install the OPTIMOST25-V4 errors appear audio channel assignment:

- Make sure that the current software is installed in the interface.
- Change the position of the interface in the MOST network (it can be installed in the course of light to the regular amplifier unit with a radio tuner or after it). The position of the device in the MOST interface can affect system initialization.
- Test the performance of two different positions of jumpers in the interface (№ 11 AUDI 3G+ Touareg NF) and (№ 13 AUDI 3G+ Lamborghini).
- Update on the regular system.
- If these other methods of neutralizing errors are impossible, it is necessary to ensure the possibility of rapid forced system initialization (e.g., by short-term gap in the supply of the MOST-RCA or MOST-TosLink) external push button or to abandon the use of the interface.

## Notes For BMW And Mercedes Benz

If the optical amplifier Logic-7 is not in the original car's specification:

- It is necessary to register in the configuration of the car using the diagnostic equipment,
- To connect the adapter, you will also need an optical cable with connector (not supplied)

## Notes For BMW

An additional mode of the OPTIMOST25-V4 (BMW spec.mode park). This mode should be used if you want to change the volume of the signal (parking sensors and system messages). Read more about this mode in the Applications.

## Notes For Mercedes Benz (Only For Comand NTG2.5)

It is necessary to activate function "Rearseat entertainment"

## Notes for Volvo (If You Have Component Protection)

Before connecting the adapter must be assigned to the adapter serial number (a marker of activity of the protection components is the cessation of broadcast audio adapter in 20-40 seconds after turning on the system).

For the assignment you need to set the jumpers to position 00 Serial Number, then, not disconnect the original amplifier, connect the OPTIMOST25-V4 to the optical interface MOST and turn on audio system. After you enable the OPTIMOST25-V4, read the serial number of original amplifier and store it in its non-volatile memory. This procedure usually takes less than 20 seconds, a sign of the end of the procedure Read Serial Number is the formation of pulses with an interval of 1 second on the line Remote (blue wire). After that you should disable original amplifier, set the jumpers to a position corresponding to the car and use the OPTIMOST25-V4 in the system instead of the original amplifier.

## Specification

Model	OPTIMOST25-V4
Type	MOST to Toslink 3.0 adaptor
Audio Output	(IEC-60958, S/PDIF) 44.1(48)kHz 24 bit stereo PCM
Power Supply	8 - 16v DC
Current (Standby)	>0.5mA
Height	1" (25mm)
Width	2.4" (60mm)
Depth	3.5" (90mm)

## International Technical Enquiries

For international technical support please contact the distribution agent for your country. Please email [export@midbass.com](mailto:export@midbass.com) for more details.

## UK Technical Enquiries

### Call 0121 311 9090 : Option 4

Or email [technical@midbass.com](mailto:technical@midbass.com)

Hours of business 9.00am - 5.30pm GMT Monday - Friday.

All calls are recorded for training purposes.

MIDBASS Distribution

PO Box 11000

B75 7WG



Designed and engineered in England



[www.vibeaudio.co.uk](http://www.vibeaudio.co.uk)

[www.youtube.com/vibeaudio](http://www.youtube.com/vibeaudio)

[www.facebook.com/vibeaudio](http://www.facebook.com/vibeaudio)

[www.instagram.com/vibeaudio](http://www.instagram.com/vibeaudio)

